

URL : <https://dgll.nic.in/>

भारत सरकार  
पत्तन,पोत परिवहन और जलमार्ग मंत्रालय  
**दीपस्तंभ और दीपपोत निदेशालय**

“दीपभवन”, गांधीनगर  
कड़वंत्रा डाक, कोचीन – 682 020

दूरभाष/ Tel :0484-  
2205720



फैक्स/ Fax: 0484-  
2206608

Government of India  
Ministry of Ports, Shipping and  
Waterways  
**DIRECTORATE OF  
LIGHTHOUSES & LIGHTSHIPS**  
“Deep Bhavan”, Gandhinagar  
Kadavanthra P.O., Cochin – 682  
020

ईमेल/ email:dte-koc@gov.in

सं. / No. MS-Coc-02012/1/2019-MS

दिनांक: 19.03.2024

### कोटेशन आमंत्रण सूचना / NOTICE INVITING QUOTATION

निम्नलिखित कार्य हेतु भारत के राष्ट्रपति के लिए और उनकी ओर से निदेशक, दीपस्तंभ और दीपपोत निदेशालय, कोचीन प्रतिष्ठित ओ ई एम या उनके अधिकृत आपूर्तिकर्ताओं, ठेकेदारों, पार्टियों या सरकारी उपक्रम से सीलबंद कोटेशन आमंत्रित आमंत्रित करते हैं। / For & on behalf of the President of India, the Director of Lighthouses and Lightships, Deep Bhavan, Gandhinagar, Kadavanthra, Cochin – 682 020 (Kerala), invites sealed quotations from reputed OEM or their authorized suppliers, Contractors, parties or Government Undertakings.

क्रम सं. SL. No.	विषय/Subject	विवरण / Description
1	कार्य का नाम / Name of Work	<b>Replacement of Lantern house outside gallery segments at Vizhinjam Lighthouse</b>
2	स्थान / Location	विझिंजम दीपस्तंभ / Vizhinjam Lighthouse.
3	अनुमानित लागत / Estimated Cost	₹ 92,900.00
4	बयाना राशि / Earnest Money Deposit (EMD)	N.A
5	कोटेशन के डाउनलोड की अवधि / Period of Download of Quotation	20.03.2024 (0900 hours) to 27.03.2024 (1400 hours)
6	कोटेशन प्रस्तुत करने की अवधि / Quotation Submission Period	20.03.2024 (1000 hours) to 27.03.2024 (1500 hours)
7	कोटेशन के खोलने की तिथि / Date of Opening of Quotation.	28.03.2024 (1500 hours)

1) कार्य का ब्यौरा निविदा दस्तावेज में उपलब्ध हैं जो केन्द्रीय सार्वजनिक खरीद पोर्टल (CPPP) वेबसाइट <http://eprocure.gov.in/epublish> से डाउनलोड किया जा सकता है और बोली केवल ऑफ़लाइन प्रक्रिया में सीलबंद कोटेशन की जा सकेगी। कोटेशन आमंत्रण सूचना विभागीय वेबसाइट [www.dgll.nic.in](http://www.dgll.nic.in) पर देखी जा सकती है। / The details of work are available in the tender document which can be downloaded from website Central Public Procurement Portal (CPPP), <http://eprocure.gov.in/epublish> and the bid is to be submitted sealed quotation in offline

procedure. The notice inviting quotation can be seen on departmental website [www.dgll.nic.in](http://www.dgll.nic.in)

- 2) ईएमडी के साथ सीलबंद कोटेशन निदेशक, दीपस्तंभ और दीपपोत निदेशालय, कोचीन - 20 को कोटेशन जमा करने की अवधि के अंतिम दिन या उससे पहले जमा किया जाना चाहिए, अन्यथा कोटेशन अस्वीकार कर दिया जाएगा। डाक/कूरियर सेवाओं के कारण होने वाली किसी भी देरी या हानि के लिए निदेशक जिम्मेदार नहीं होंगे / Sealed Quotation with EMD should be submitted to The Director, Directorate of Lighthouses and Lightships, Cochin – 20 on or before the last day of quotation submission period failing which the quotation shall be liable to be rejected. Director shall not be responsible for any delay or loss, due to postal/Courier Services.
- 3) यह अनुबंध सभी मामलों में और भारतीय कानूनों के अनुरूप एक भारतीय अनुबंध के रूप में तैयार और संचालित किया जाएगा। अनुबंध कार्यों के संबंध में या उससे उत्पन्न होने वाले कानूनी मुकदमे और अन्य कार्यवाही कोच्चि (एर्नाकुलम), केरल के कानून न्यायालयों में शुरू की जाएंगी। This contract shall be framed and operated as an Indian Contract in all the respects and in conformity with Indian laws. Law suits and others proceedings arising out of or in connection with the contract works shall be instituted in Courts of Law of Kochi (Ernakulam), Kerala.

निदेशक / DIRECTOR

## SCOPE OF THE WORK

- i. Supply and Installation of materials to the site, Vizhinjam Lighthouse, Vizhinjam Lighthouse, Vizhinjam (PO), Thiruvananthapuram Dist., Kerala, Pin: 695521 Including Loading, Unloading and Freight charges.
- ii. Installation, Integration and Commissioning should be carried out by your representative in presence of department representative at site.
- iii. Fabrication of Lantern house outside gallery segments at Vizhinjam Lighthouse (02 Nos Plates) as mentioned in drawing, profile cutting of the Chequered sheets needs to be carried as per the drawing. However, actual size and shape of chequered sheet may vary according to the site condition. Side Strip 20 mm x 20 mm needs to be welded on 02 Nos Chequered Sheets as mentioned in the drawing.
- iv. Drilling of 10 mm Diameter Holes with 3 mm X 45 Degree Chamfer 10 Nos in Each Chequered plate, Total 60 Holes (10 Holes x 06 Nos Chequered plate) as mentioned in the drawing.
- v. Fastening of the above Chequered plate in Outside Gallery segments in the top of the Lighthouse tower using Fasteners M10 / M12 x 60 mm Hex Bolts (08 Nos), M10/ M12 Nuts (08 Nos), M10/M12 Washers (16 Nos). Material- Stainless Steel, Make- Unbrako, TVS, Or any Reputed Make, Grade SS 316 (A4- 70/80) or SS 304 (A2- 70/80).
- vi. Painting of all the 06 nos of Chequered plate (02 no's new and 04 no's existing) and Complete assembly (Old Paint to be scrapped and new coat to be applied). with 02 coats of anti-rust epoxy primer and 02 coats of enamel paint.
- vii. Scaffolding to be constructed by the bidder for safety of worker/ Labour.
- viii. The work should comply with following specifications:
  - All the Materials for the works should be as per the specifications, make and model as mentioned in Annexure I (Schedule of work).
  - The requirements shown in the schedule are indicative only. The measurement of the same shall be taken as per actuals (weight, dimension and Qty as applicable) at the site; the payment shall be made accordingly.
  - The bidders are advised in their own interest to visit the proposed site of work to get acquaint themselves with the site and the working conditions as also the nature and minimum standard of work expected of them.

All above items to be of reputed make as and where required conforming to relevant Indian standards.

बोलीकर्ता / BIDDER

निदेशक / DIRECTOR

## TERMS AND CONDITIONS

- i. Your quotation may be forwarded in a sealed cover duly super scribed **“Replacement of Lantern house outside gallery segments at Vizhinjam Lighthouse”** so as to reach this office ,**Directorate of Lighthouses and Lightships, Deep Bhavan, Gandhinagar, Kadavanthra, Cochin – 682 020 (Kerala)**, on or before 1500 hours on 27.03.2024, which shall be opened on 28.03.2024 ( 1500 hours).
- ii. Your rate shall indicate the basic cost and other taxes separately.
- iii. The items used should be of standard make and confirm to the Indian standard specification as applicable.
- iv. All items mentioned in schedule should be in good condition, if desired the department representative may visit for observing condition of the items. Warranty in respect of each item shall clearly be specified.
- v. Technical brochure, Drawing, Specification sheets of the product shall be furnished along with the quotation, if applicable, as required.
- vi. The following documents to be submitted along with sealed quotation:
  - 1) PAN card.
  - 2) GST Registration Certificate, if applicableNon Submission of any of above credentials shall render the quotation liable for rejection.
- vii. The L1 bidder shall be decided on the consolidated lowest total of the schedule of work.
- viii. The work shall be carried out to the entire satisfaction of the Director or his representative.
- ix. The payment shall be made as below:
  - 1) 100% payment of the contract amount shall be made within 30 days from the satisfactory installation/ completion of work.
- x. The rates should remain valid for 60 days from the date of opening of quotations. The work shall be made within 30 days from the date of work order.
- xi. The right to reject your offer either in part or in full without assigning any reasons vests with the undersigned.
- xii. The Director, Directorate of lighthouses and Lightships, Cochin reserves the right to cancel the contract if the contractor is found not working according to the terms and conditions, and he will be liable to make good of the losses of the department due to the breach of any of the terms and conditions of the contract for the period up to the date of actual termination of the contract.

बोलीकर्ता / BIDDER

निदेशक / DIRECTOR

**ANNEXURE - I****अनुसूचि / SCHEDULE****कार्य का नाम / Name of Work :- Replacement of Lantern house outside gallery segments at Vizhinjam Lighthouse**

क्रम सं. S. No.	वस्तु का विवरण Description of items	मात्रा Qty	रेट Rate	जी एस टी / GST (In %) and in ₹	यूनिट Unit	रकम Amount in ₹
1.	Fabrication and Installation Charges for 02 Nos chequered sheets Including profile cutting, and drilling 04 Nos of mounting holes in each Chequered sheet (02 Nos Newly fabricated), and fabrication of Side strip of 20 mm x 20 mm for 02 Nos Chequered sheets newly fabricated as mentioned in the drawing and as per actuals at site. <u>Specifications:</u> 1.Chequered Plates -10 mm Thickness, IS – 3502, Material- MS., 2.Side Strip – 20 mm x 20 mm, MS 3.Fasteners _ M 12 X 60 mm Grade- SS 316 (A4- 70/80) or SS 304 (A2-70/80).					
2.	Labour charges for drilling of 10 mm (Chamfer 3 mm X 45 Degree) diameter Holes at equal distance in all the 06 Nos chequered plates (04 existing and 02 newly fabricated). (10 Nos holes in each plates).					
3	Supplying of Painting materials (Paint, Thinner, Primer) and Painting 06 no's of Chequered plate (02 no's new and 04 no's existing) and Complete assembly with 02 Coats of anti Rust Epoxy Primer and 02 Coats of Enamel Paint (Black/ White) Paint with Good Surface finish.					
4.	Transportation, Loading / Unloading and Lifting charges of Materials/ Equipment's to top of the Lighthouse tower at Vizhinjam Lighthouse.					
<b>Grand Total</b>						
Rupees						
only)						

बोलीकर्ता / BIDDER

निदेशक / DIRECTOR

# CHEQURED PLATE DESIGN

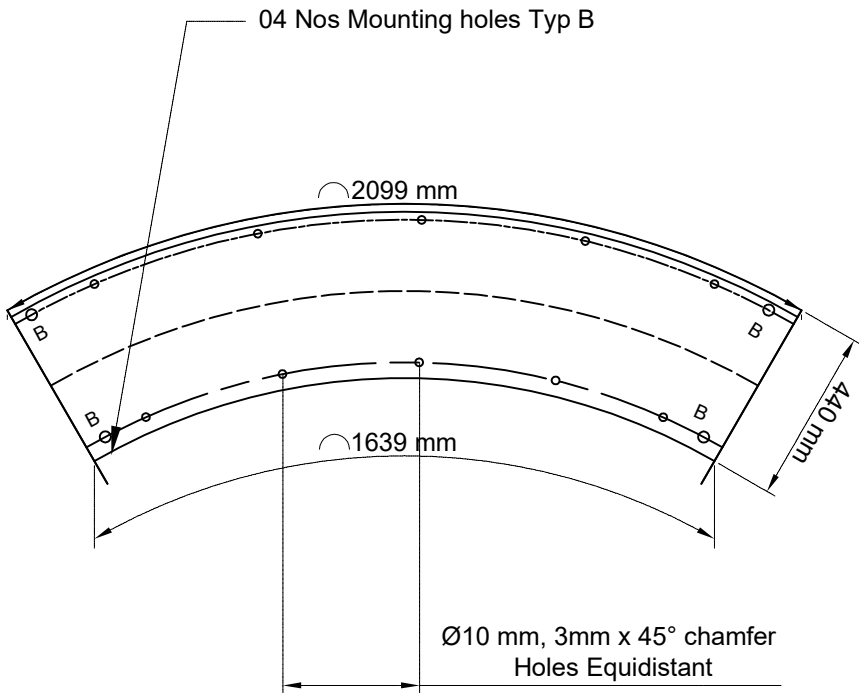
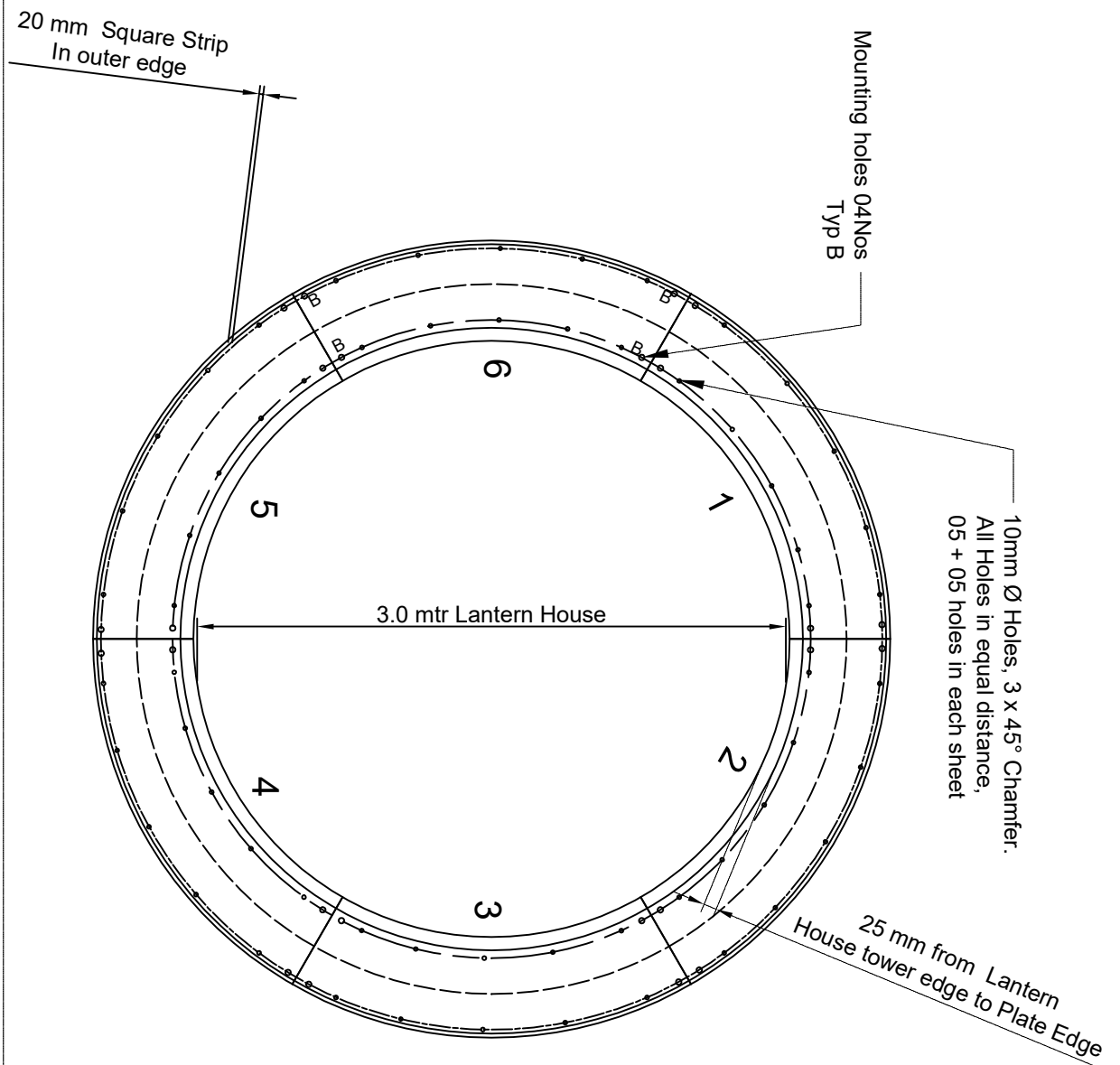

Plate- Mild Steel Chequered Sheet 10 mm Thickness  
Side Strip - Mild Steel (20 mm X 20 mm)



\* Out side gallery is made up of 06 Nos of Chequered  
Sheets out of which 02 Nos are to be replaced.

## Lantern House Outside Gallery Segments